

УДК 517.9:621.325.5:621.382.049.77

M. KOSOVETS,

SPE «Quantor», Kyiv, Ukraine

GENERATING A TEST CONFIGURATION WITH ABSORBER 3D TERAHERTZ FMCW IMAGING RADAR

We have been investigating the possibility of forming tests for different system configurations and materials depending on the distance between the sample and the antenna using absorber.

Keywords: absorber; digital spectral analysis; electromagnetic simulator; horn antenna; average basic function (BF); mixed signal (MS).

Introduction

In scientific laboratory SPE «Quantor» designed and manufactured **FMCW** (*Frequency Modulation Continuous Wave*) radar with the following parameters: frequency band linear; frequency modulation — from 92 to 96 GHz; period (length of interval) — 1 ms; bit ADC — from 16 to 32 bits; the number of cycles of accumulation — from 1 to 10 000; layers reflection — 3; distance to layers reflection — 0.095; 0.105; 0.106 m; wave propagation environment — air; signal-to-noise ratio — from 80 to 30 dB.

In the implementation of 3D scanning small objects is used FMCW radar of terahertz frequency range (fig. 1).

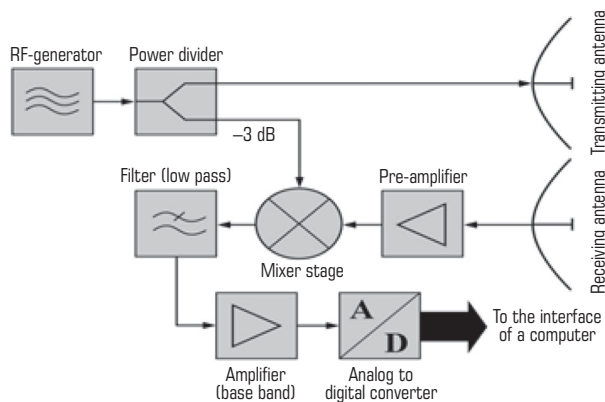

Fig. 1. Microwave part 3D FMCW terahertz radar

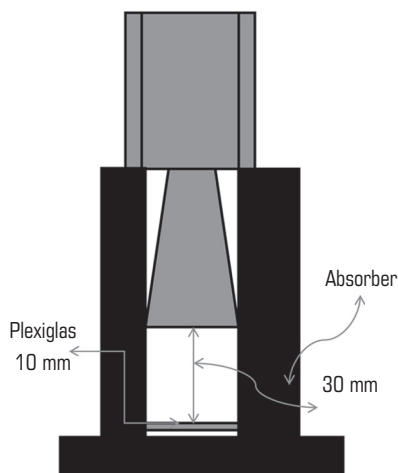

Fig. 2. System for testing 3D radar

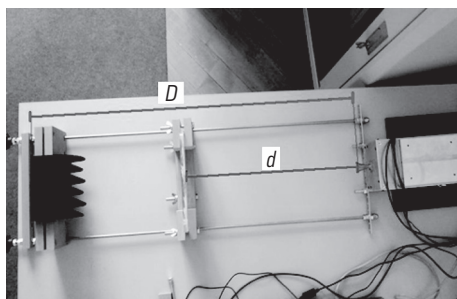

Fig. 3. New system head 3D

We have used conical horn antenna. The main characteristics of the various methods of spectral estimation parameters of signals were tested in order to studied materials (fig. 2).

There was conducted testing using configuration:

- distance horn – sample is equal 30 mm;
- thickness of the sample is equal 10 mm;
- distance horn – absorber in the bottom is equal 40 mm;
- horn is surrounded by absorber.

In this condition:

1. We measured the signal without the sample (5 times) and noting in the folder «Background».

2. We placed the sample (plexiglas of 10 mm) on the absorber and repeated the measure 5 times then noting folder «Plexiglas 10 mm».

3. On the top of the sample we stick a thin conducting film (carbon fiber of 0.4 mm) and repeat the measure 3 times then noting folder «Plexiglas and carbon-up».

4. We flipped back the sample with the film conducting and repeated measure 3 times then noting folder «Plexiglas and carbon-down».

We did some additional tests using:

- only the layer of carbon fiber placed on the absorber and noting folder «Carbon»;
- layer of kevlar/diolen (thickness is 1.5 mm) placed on the absorber and noting folder «Kevlar/diolen».

Measurements in system

The new system is shown in the fig. 3 and the maximum distance at which the absorber can be placed with respect to the antenna is $D = 80$ cm.

The measurements were made as following:

1. Measuring without sample moving the absorber from 10 to 80 cm with 5 cm step.

2. Using a single material at the same time: plexiglas (fig. 4) and layer of kevlar/diolen (fig. 5).

3. Putting the sample at $d = 30$ cm and making measurements increasing the distance from the Horn beginning in 1 mm at a time until reaching the distance of 31 cm.

4. From this position (31 cm), moving the sample increasing the distance from the horn of 1 cm in the same time until reaching the distance of 40 cm.

© M. Kosovets, 2017

5. Repeating paragraphs 1-3 using two plates like a «sandwich» (plexiglas + PVC). The first one (in front the horn) must be homogeneous and weakly absorbing (we use plexiglas — fig. 6).

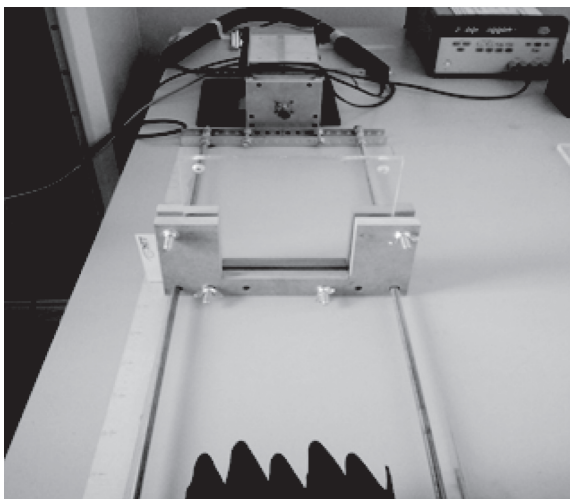

Fig. 4. Setup using plexiglas sample

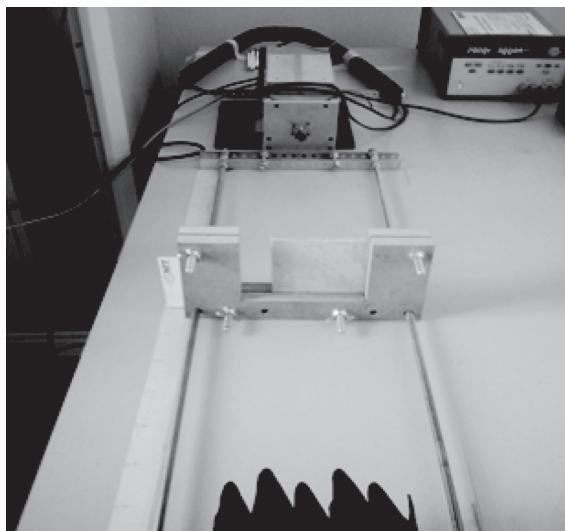

Fig. 5. Setup using kevlar/diolen sample

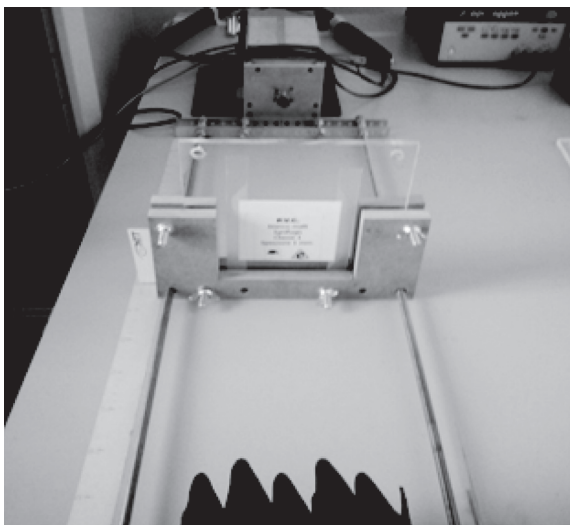

Fig. 6. Setup using plexiglas and PVC sample

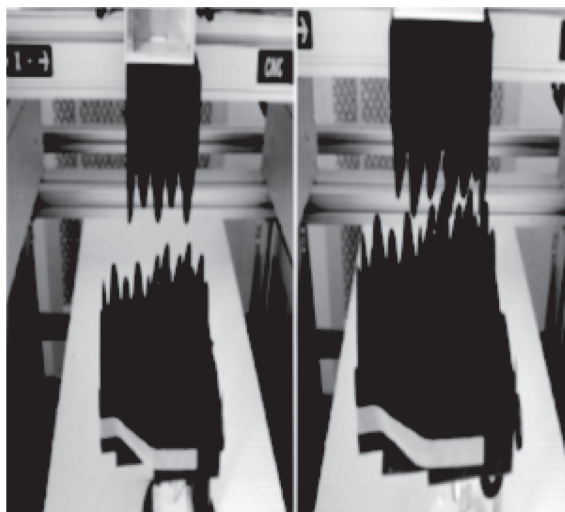

Fig. 7. Reflection plane is a 6 x 6 metal plane

Computing and modelling (fig. 8–30)

Width of emission beam in this case maybe a larger then 6 mm diameter, but only when 6 x 6 mm square we put a reflection beam (fig. 7). This is proof, that emission beam with 6 mm diameter must produce a simple results. In next measurements we have a less distance from horn to samples and must have a larger signals, but we have not this. This is proof, that center of hole is not in focus of beam in the following measurements. The more size of series, the less approximation error of 4×10 .

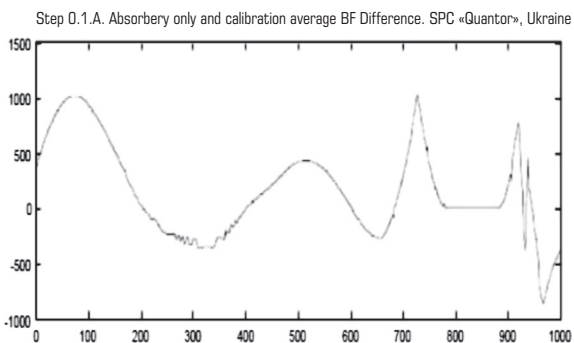

Fig. 8. Estimation of calibration result (STEP 0.1.B. Absorber only and calibration average BF)

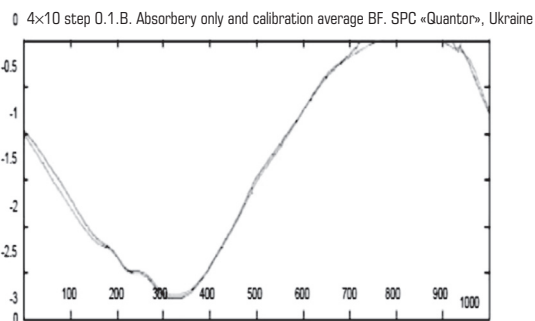

Fig. 9. Estimation of calibration results (4 x 10 step 0.1.B. Absorber only and calibration average BF. SPC «Quantor», Ukraine)

The more size of series, the less approximation error of non-removable response

We can see an average basic functions (BF) of 40 response signals from 6×6 mm metal at 40 different distances — estimation of non-removable response from constructive elements (horn and others), and average BF of 40 response signals from absorber only without metal plane [1]. We can see a small difference between absorber only average BF and calibration (by metal) average BF. It isn't normal, but not so full tragedy.

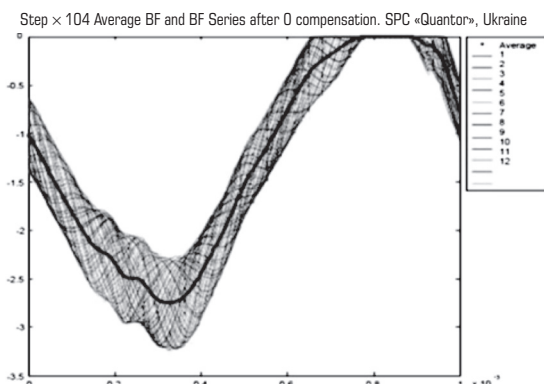

Fig. 10. Comparing an average BF and series of BF

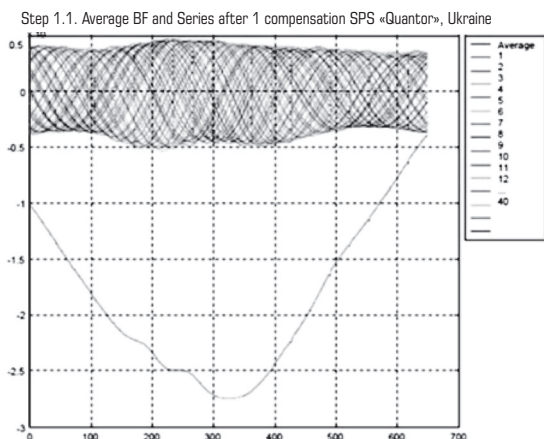

Fig. 11. Results of compensation of non-removable response from BF series

Curve bold — average BF (non-removable response). Curve 1–40 — series of BF for different 40 distances. It is a good result.

The new series of compensated basic functions is estimation of elementary responses from 40 different distances.

In this test we will be used an each non-compensated calibration BF as simple composed mixer signal (MS) [2], what fully corresponded to fig. 6, because BF series is used in another role. We will estimated a distance spectrum for each of 40 non-compensated calibration BF in a new signal basis (basis of new compensated BF).

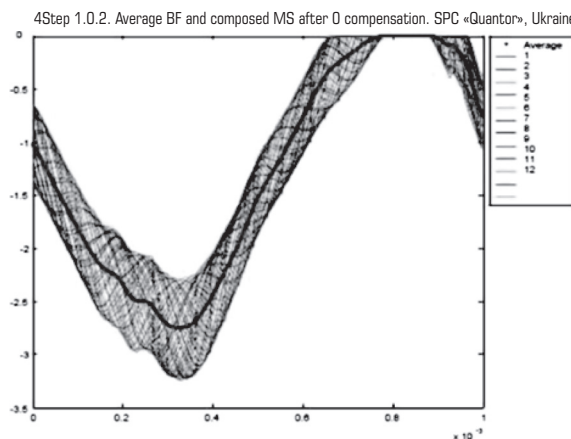

Fig. 12. Series of simple «Composed Mixer Signal» that will be used to test a new compensated BF

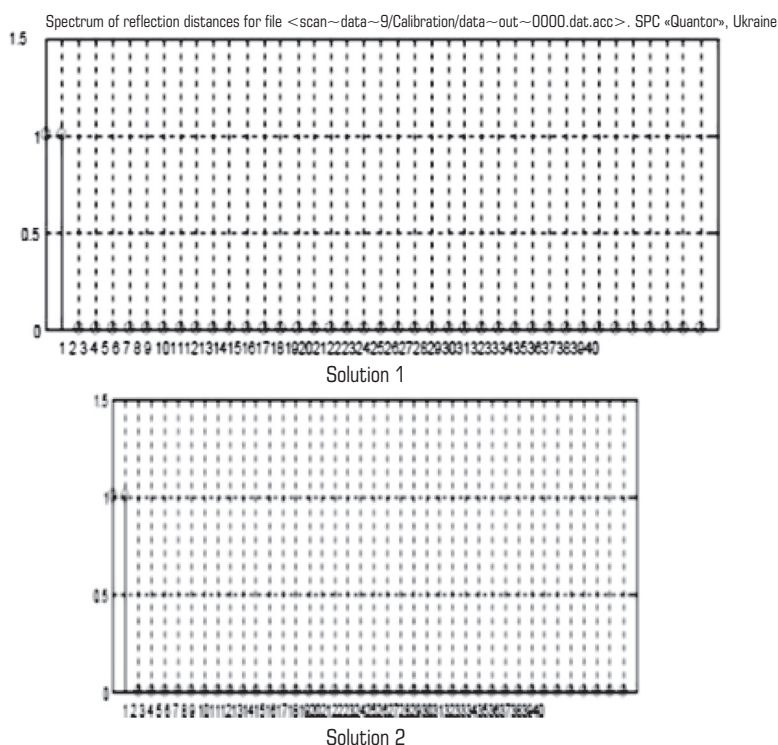

Fig. 13. Distance spectrum for 1-st test composed mixer signal (1-st non-compensated BF)

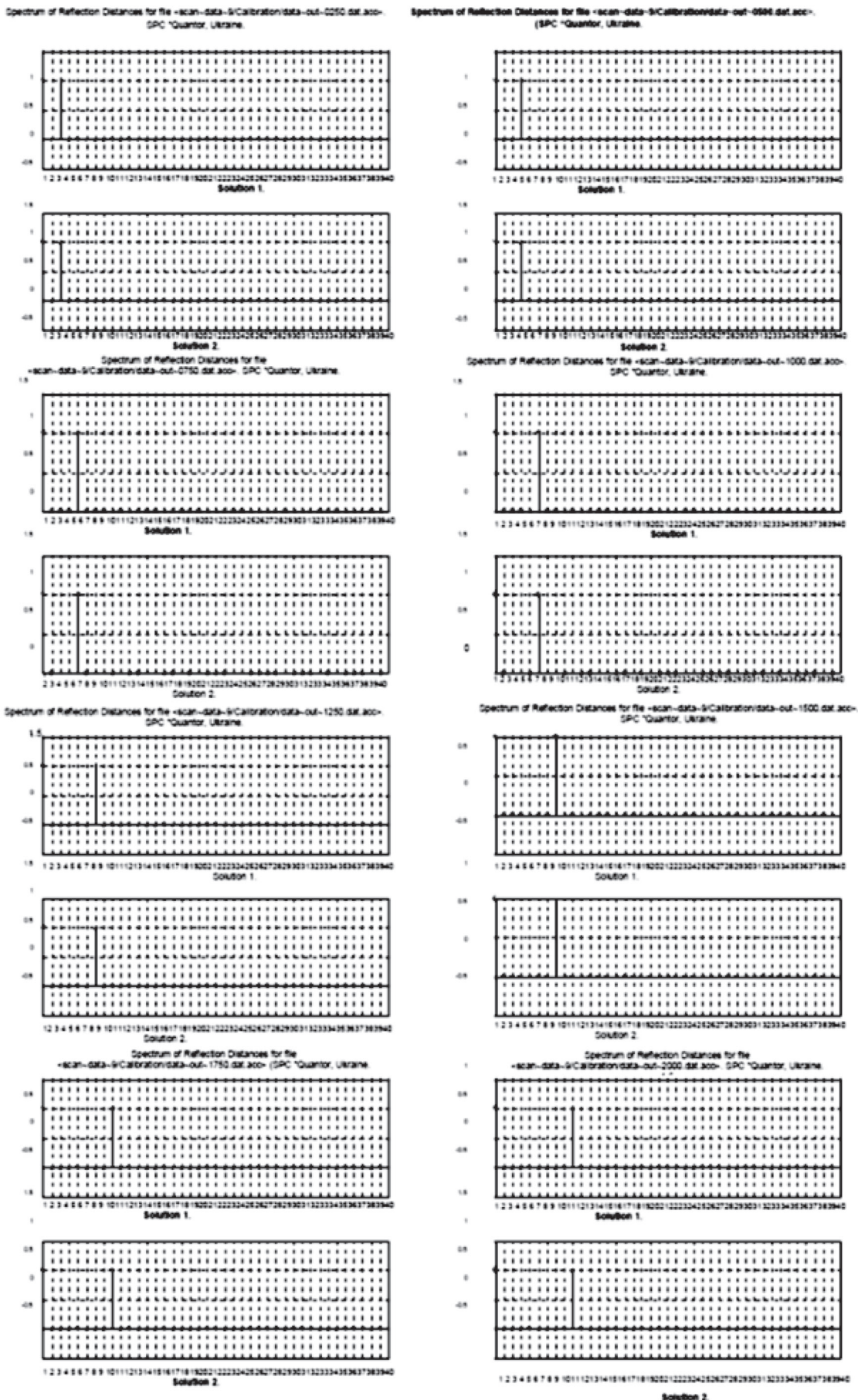

Fig. 14. Distance spectrum for basic functions №2, ..., 9

We can see an excellent result! 1-st test composed MS is consisting only from an average BF (BF №0) and 1-st compensated BF. None other basic functions are not have a weight in a test mix.

We have a not orthogonal signal basis, but we work with this basis and have results like results for orthogonal signal basis: each BF produce unit weight with itself and zero weights with any other BF. But when we will have response from plane, which is between distance grids we will have worst results.

We will see that signal energy is leaked to all BF. To decrease an influence of this effect and to increase accuracy of distance spectrum estimation we can decrease a step of distance while calibration (up to 50 μm , for example). We will have a 200 BF [3].

Restore MS for file4 can--data~/9/Calibration/data~/out~/0000.dat.acc>. SPC «Quantor», Ukraine

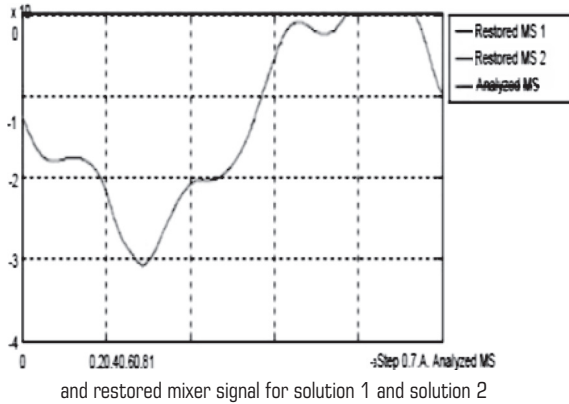

and restored mixer signal for solution 1 and solution 2

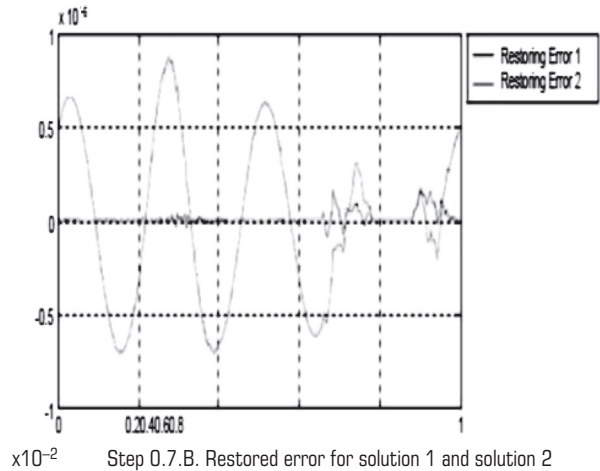

Step 0.7.B. Restored error for solution 1 and solution 2

Fig. 15. Attempt to restore a test signal (non-compensated BF №1). We can see that restoring error is very small

Total result for calibration is normal. Now we can continue measuring. We look at the different materials with the same size.

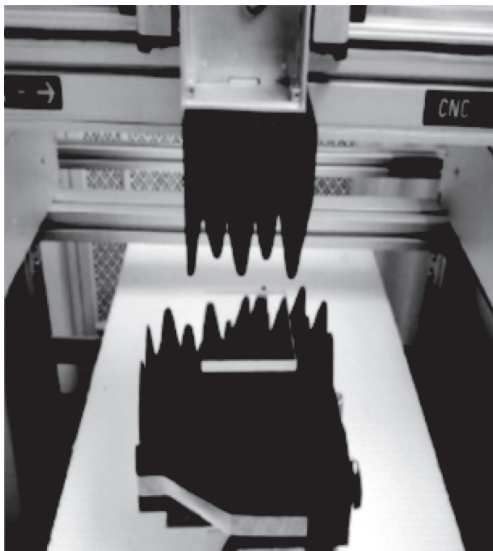

Fig. 16. Plexiglas 100 × 100 × 10 mm

4Step 1.0.2. Average BF and composed MS after 0 compensation. SPC «Quantor», Ukraine.10

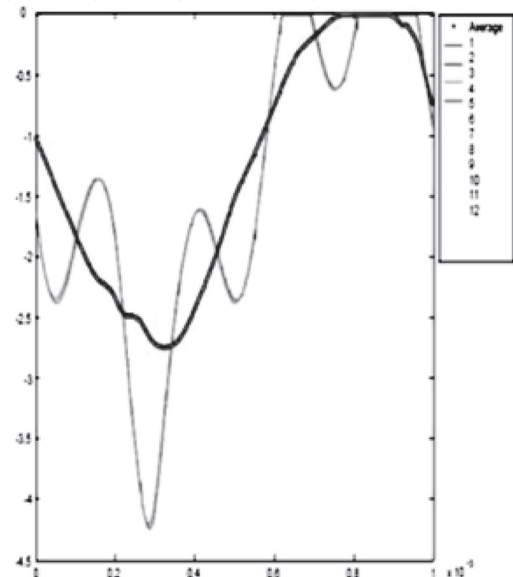

Fig. 17. Non-removable response from horn and response from plexiglas 100 × 100 × 10 mm

Curve bold — average BF of 40 response signal from 6 × 6mm metal at 40 different distance — estimation of non-removable response from constrictive elements (horn and others), curve 1-4 — mix of non-removable response from horn and large (good result) useful signal from plexiglas 100 × 100 × 10 mm.

Thickness of 10 mm must give a composed mixed signal with 2 elementary responses, that according to BF №1 and BF №40 (approximately). Really we can see 1-st maximum for BF №39 (the last BF №40 was been removed from analyze to protect matrix singularity) and 2-nd maximum for BF №1 and 2 (that corresponding to case, when reflection plane is between distance №1 and 2):

- BF № 01.085535 — part of composed mixed signal by non-removable response (average BF);
 - BF № 39-1.180438 — part of composed MS by 1-st reflection plane of sample with 10 mm thickness;
 - BF № 1-2.276038 — part of composed MS by 2-nd reflection plane of sample with 10 mm thickness;
 - BF № 2-2.502144 — part of composed MS by 2-nd reflection plane of sample with 10 mm thickness;
- All composed MS for plexiglas 100 × 100 × 10 mm gives very similar distance spectrum.

Spectrum of reflection distances for file <scan~data~9\Plexiglas\Plexiglas1.dat.acc>. SPC «Quantor», Ukraine

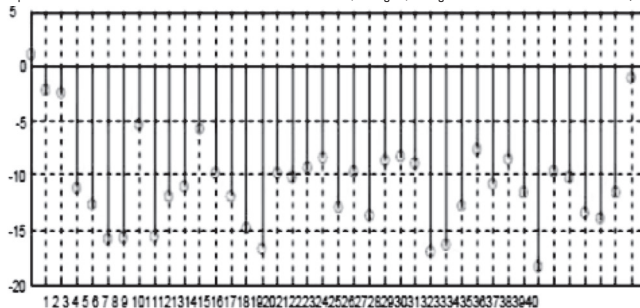

Solution 1

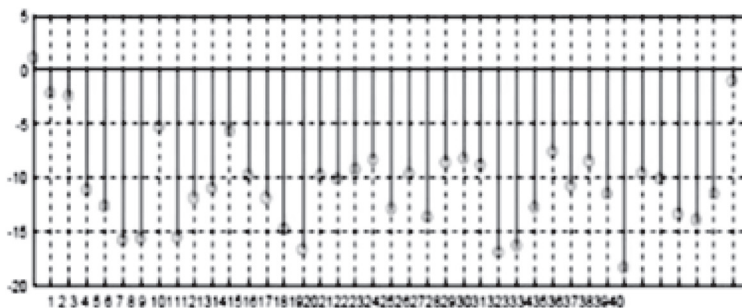

Solution 2

Fig. 18. Distance spectrum for plexiglas 100 × 100 × 10 mm

Restore MS for 4file <scan~data~9\Plexiglas\Plexiglas1.dat.acc>. SPC «Quantor», Ukraine

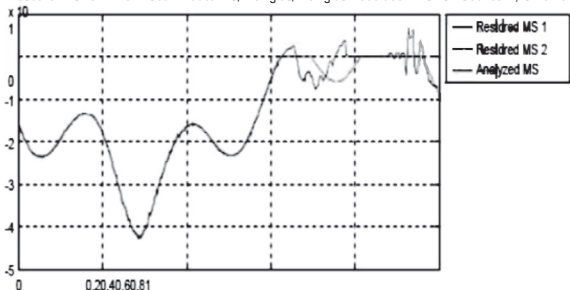

Step 0.7.A. Analyzed mixer signal and restored mixer signal for solution 1 and solution 2

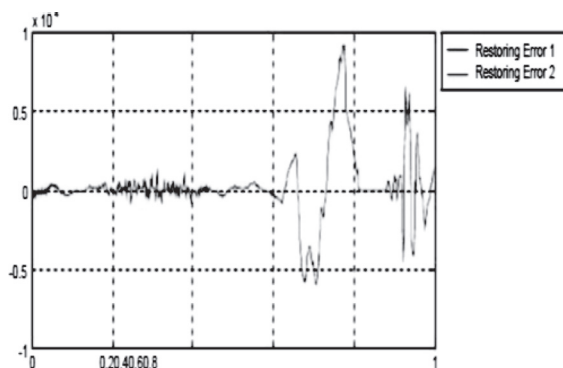

Step 0.7.B. Restored error for solution 1 and solution 2

Fig. 19. Attempt to restore source composed mixed signal from calculated distance spectrum

We can see a good restoring (from 0 to 0.6 ms, where error was been minimised), that is proof that distance spectrum is true [4].

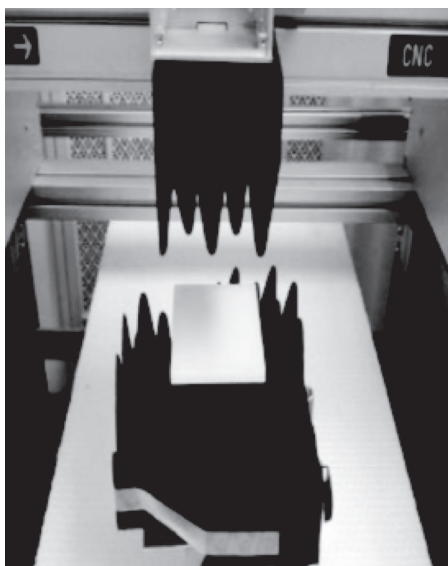

Fig. 20 - Opale 100x100x10 mm

4Step 1.0.2. Average BF and composed MS after 0 compensation. SPC «Quantor», Ukraine

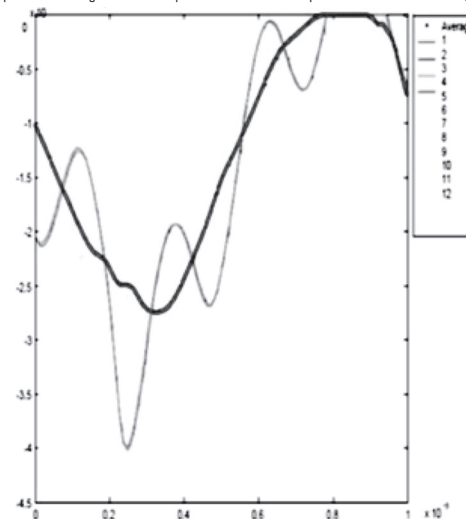

Fig. 21. Non-removable response from horn and response from opale 100 × 100 × 10 mm

Curve bold — average BF of 40 response signals from 6 × 6mm metal at 40 different distances — estimation of non-removable response from constrictive elements (horn and others), curve 1–4 — mix of non-removable response from horn and large useful signal from opale 100 × 100 × 10 mm. We can see another phase of composed MS with compare to fig. 10 for plexiglas 100 × 100 × 10 mm.

Spectrum of reflection distances for file <scan~data~9\Opale\Opale1.dat.acc>. SPC «Quantor», Ukraine

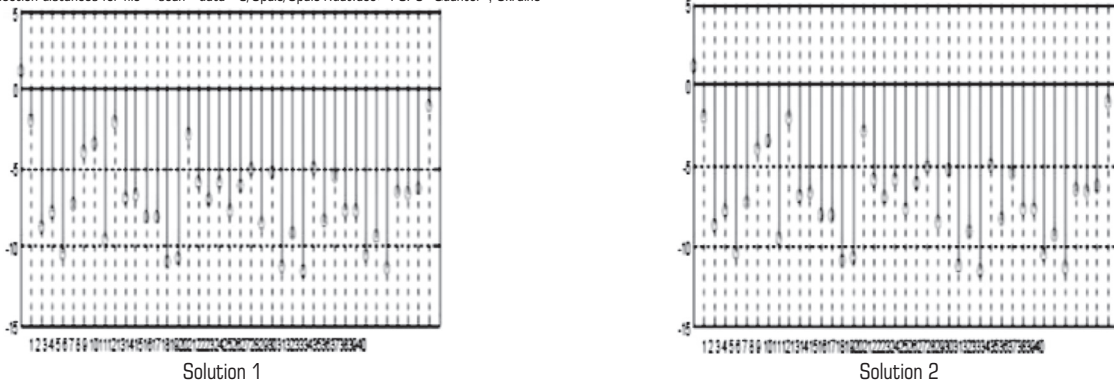
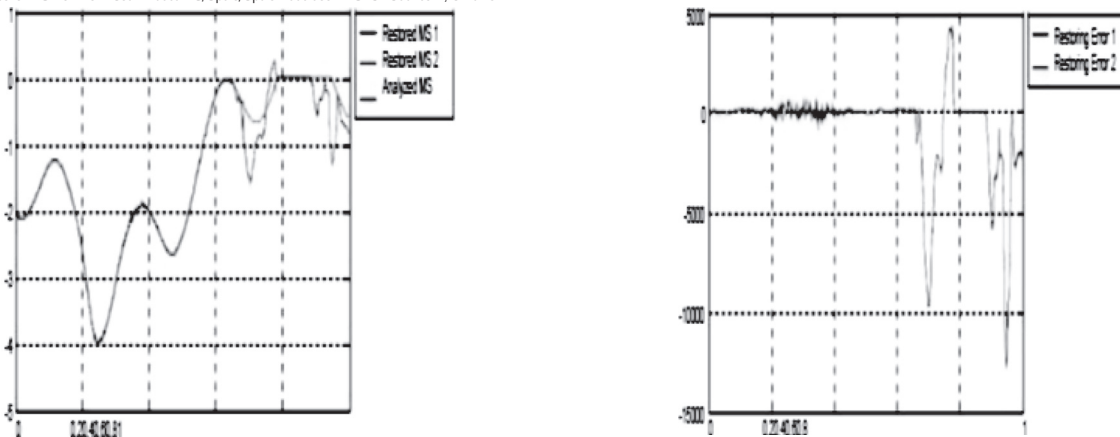

Fig. 22. Distance spectrum for opale 100 × 100 × 10 mm

We can see result like result at fig. 22. Thickness of 10 mm must give a composed MS with 2 elementary responses, that according to BF №1 and 40 (approximately). Really we can see 1-st maximum for BF №39 (the last BF №40 was been removed from analyze to protect matrix singularity) and 2-nd maximum for BF №1:

- BF № 0 - 1.078931 — part of composed MS by non-removable response (average BF);
 - BF № 39 - 1.071220 — part of composed MS by 1-st reflection plane of sample with 10 mm thickness;
 - BF № 1 - 1.988772 — part of composed MS by 2-nd reflection plane of sample with 10 mm thickness;
- All 4 composed MS for opale 100 × 100 × 10 mm gives very similar distance spectrum.

RestorexMS4 for file <scan~data~9\Opale\Opale1.dat.acc>. SPC «Quantor», Ukraine



Step 0.7.A. Analyzed mixer signal and restored MS for solution 1 and solution 2

Step 0.7.B. Restored error for solution 1 and solution 2

Fig. 23. Attempt to restore source composed MS from calculated distance spectrum

We can see a good restoring (from 0 to 0.6 ms, where error was been minimised), that is proof that distance spectrum is true.

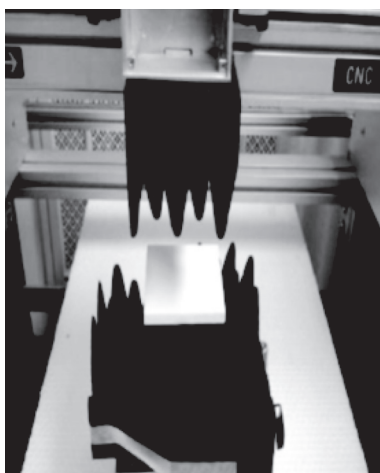

Fig. 24. Forex 100 × 100 × 10 mm

4Step 1.0.2. Average BF and composed MS after 0 compensation. SPC «Quantor», Ukraine

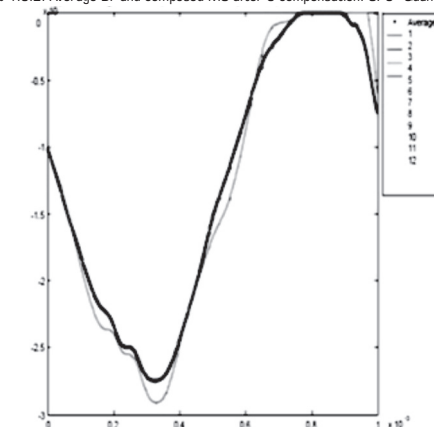

Fig. 25. Non-removable response from horn and response from forex 100 × 100 × 10 mm

Curve bold — average BF of 40 response signals from 6 × 6mm metal at 40 different distances — estimation of non-

Removable response from constrictive elements (horn and others), curve 1–4 — mix of non-removable response from horn and useful signal (it is not very large, but not to very small) from forex 100 × 100 × 10 mm [5].

Spectrum of reflection distances for file <scan--data~9\Opale\Opale1.dat.acc>. SPC «Quantor», Ukraine



Fig. 26. Distance spectrum for forex 100 × 100 × 10 mm

We can see a completely different result with compare to fig. 14 and 18.

We can see 1-st maximum for BF №4 and, maybe, artefact or 2-nd maximum for BF №28 and 29 (that corresponding to case, when reflection plane is between distance №28 and 29). We don't known comment for this result, maybe work distance was been set to distance №4:

- BF № 41.528165 — maybe a part of composed MS by 1-st reflection plane of sample;
- BF № 291.355021 — maybe a artefact or part of composed MS by 2-nd reflection plane of sample;
- BF № 281.338123 — maybe a artefact or part of composed MS by 2-nd reflection plane of sample;
- All 4 composed MS gives lightly different distance spectrum.

RestorexMS4 for file <scan--data~9\Opale\Opale1.dat.acc>. SPC «Quantor», Ukraine

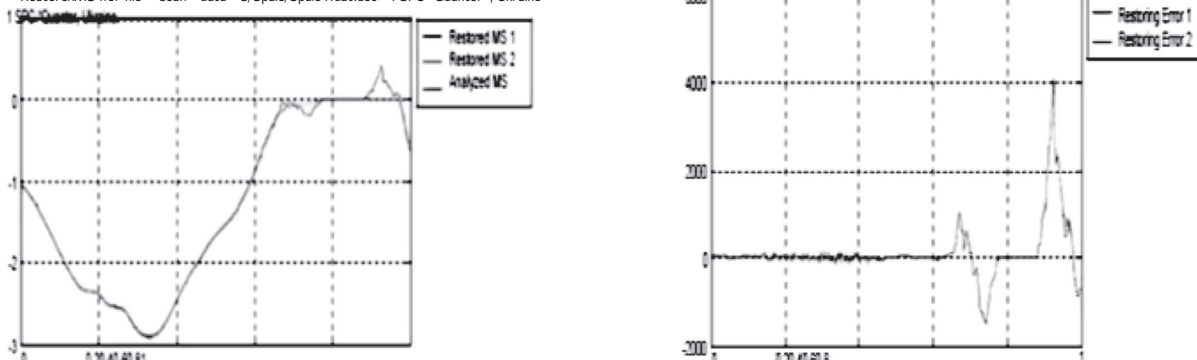

Step 0.7.A. Analyzed MS and restored MS for solution 1 and solution 2

Step 0.7.B. Restored error for solution 1 and solution 2

Fig. 27. Attempt to restore source composed MS from calculated distance spectrum

We can see a good restoring (from 0 to 0.6 ms, where error was been minimised), that is proof that distance spectrum is true.

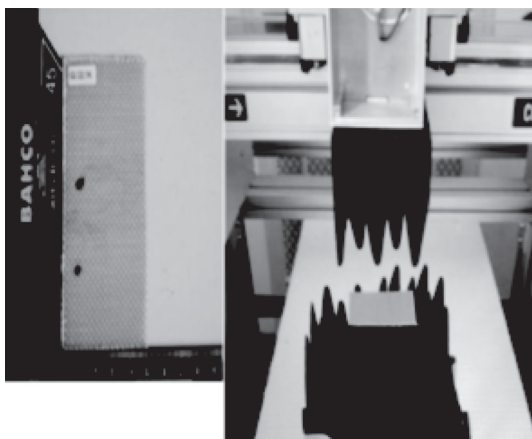

Fig. 28. Kevlar 10 × 5 × 0.35 mm

4Step 1.0.2. Average BF and composed MS after 0 compensation. SPC «Quantor», Ukraine

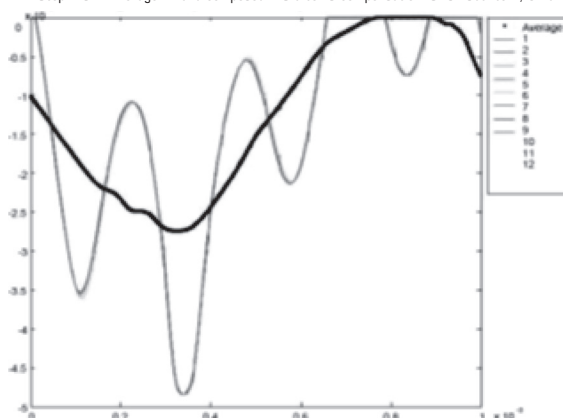

Fig. 29. Non-removable response from horn and response from kevlar 10 × 5 × 0.35 mm

Curve bold — average BF of 40 response signals from 6×6 mm metal at 40 different distances — estimation of non-removable response from constrictive elements (horn and others), curve 1–8 — mix of non-removable response from horn and large (good!) useful signal from kevlar $10 \times 5 \times 0.35$ mm.

Spectrum of reflection distances for file <scan~data~9\Opale\Opale1.dat.acc>. SPC «Quantor», Ukraine

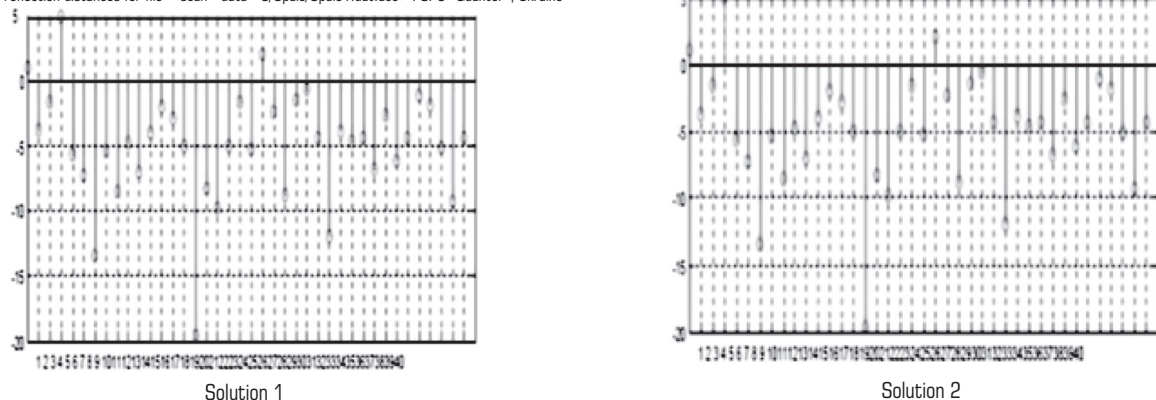

Fig. 30. Distance spectrum for kevlar $10 \times 5 \times 0.35$ mm

We can see a result like result at fig. 14 and 18, but for less thickness of sample.

We can see 1-st maximum for BF №3 and, maybe, artefact or 2-nd maximum for BF №21.

BF № 34.961173 — maybe a part of composed MS by 1-st reflection plane of sample.

BF № 212.024414 — maybe a artefact or part of composed MS by 2-nd reflection plane of sample.

But we know that thickness of sample is 0.35 mm and this is not to correspond to distance spectrum. We need to make additional tests.

Conclusion

To increase accuracy of distance spectrum estimation we can try to decrease size of distance step up to 50 cm. We must make revision, if the centre of hole is in the focus of beam. We can try to repeat every measurement a some times, for base distance $D1$, $D2 = D1 + 1000$ cm, $D3 = D1 + 2000$ cm, for example. A good measurement techniques is to make an additionally calibration with absorber only with step 1 mm.

Список використаної літератури

1. Косовець, М. Оцінювання параметрів характеристичних функцій 3D терагерцового радара / М. Косовець, О. Павлов, В. Смірнов: зб. тез VI міжнар. наук.-техн. симпозіуму «Нові технології в телекомунікаціях», ДУИКТ – Карпати'2013.— Вишків, 21-25 січня 2013.— С. 174–179.
2. Косовець, М. Signal processing 3D Terahertz Imaging FMCW Radar for the NDT of Material / Н. Косовець, А. Дробик, W. Кнар: сб. тезисов VI Междунар. науч.-техн. симпозиума «Новые технологии в телекоммуникациях», ГУИКТ – Карпаты'2013.— Вышков, 21-25 января 2013.— С. 154–156.
3. Kalman, R. E. A New Approach to Linear Filter in Prediction Problems / R. E. Kalman // Transactions. Journal of Basic Engineering.— 1982.— (SeriesD).— P. 35–45.
4. Косовець, Н. А. Моделирование нелинейных элементов цифрового 3D радара // Зв'язок.— 2016.— №2.— С. 40–47.
5. Kosovets, M. Modeling conical horn antenna of 3D terahertz FMCW radar / М. Kosovets, L. Tovstenko // Зв'язок.— 2016.— №5.— С. 43–50.

Рецензент: канд. техн. наук, професор О. В. Дробик, Державний університет телекомунікацій, Київ.

Н. А. Косовець

ФОРМИРОВАНИЕ ТЕСТОВЫХ КОНФИГУРАЦИЙ С ПОГЛОТИТЕЛЕМ 3D ТЕРАГЕРЦОВОГО ЛЧМ РАДАРА ИЗОБРАЖЕНИЯ

Исследованы возможности формирования тестов при различных конфигурациях системы и материалов зависимости от расстояния между образцом и антенной с использованием поглотителя.

Ключевые слова: поглотитель; цифровой спектральный анализ; электромагнитный имитатор; рупор антенны.

Н. А. Косовець

ФОРМУВАННЯ ТЕСТОВИХ КОНФІГУРАЦІЙ З ПОГЛИНАЧЕМ 3D ТЕРАГЕРЦОВОГО ЛЧМ РАДАРА ЗОБРАЖЕННЯ

Досліджено можливості формування тестів для різних конфігурацій системи та матеріалів залежно від відстані між зразком і антеною з використанням поглиначча.

Ключові слова: поглинач; цифровий спектральний аналіз; електромагнітний імітатор; рупор антени.